

# THE LYNTON AND BARNSTAPLE RAILWAY

Passenger Rolling Stock Built By  
The Bristol Carriage & Wagon Works 1898

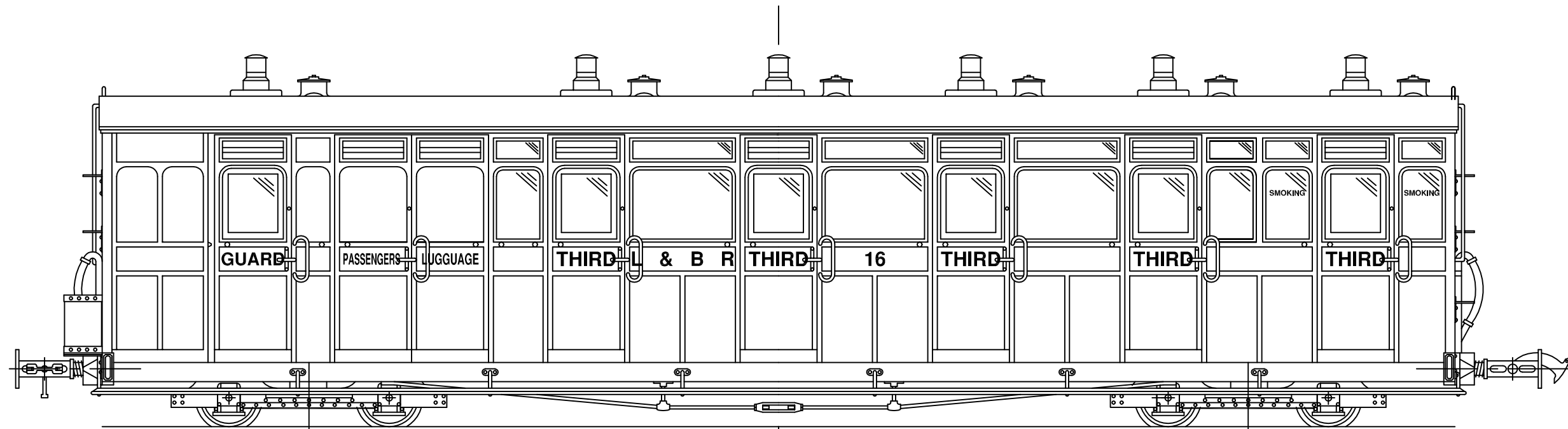

COACH No. 16 - THIRD BRAKE  
SOUTHERN RAILWAY No. 4108

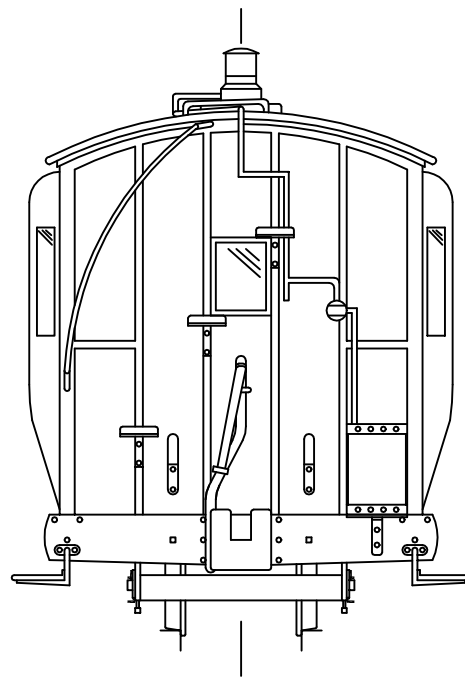

Length: 35' 2"  
Width: 6' 0"  
Height: 8' 7"  
Weight: 9Tons 0cwt  
Seats: 40 Third Class

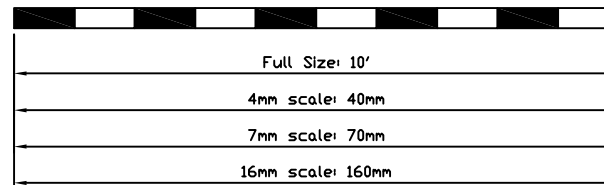
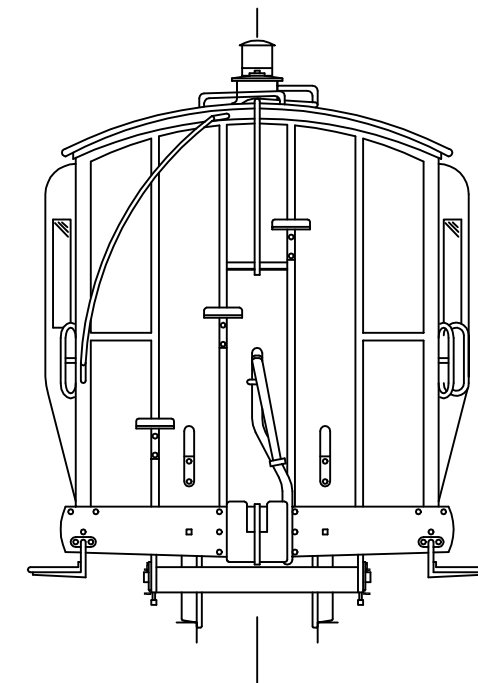

SCALE : 8mm = 1'  
FILE : LBPRS15.DWG

R Wilkinson 1/2006