

THE LYNTON AND BARNSTAPLE RAILWAY

Passenger Rolling Stock Built By
The Bristol Carriage & Wagon Works 1898

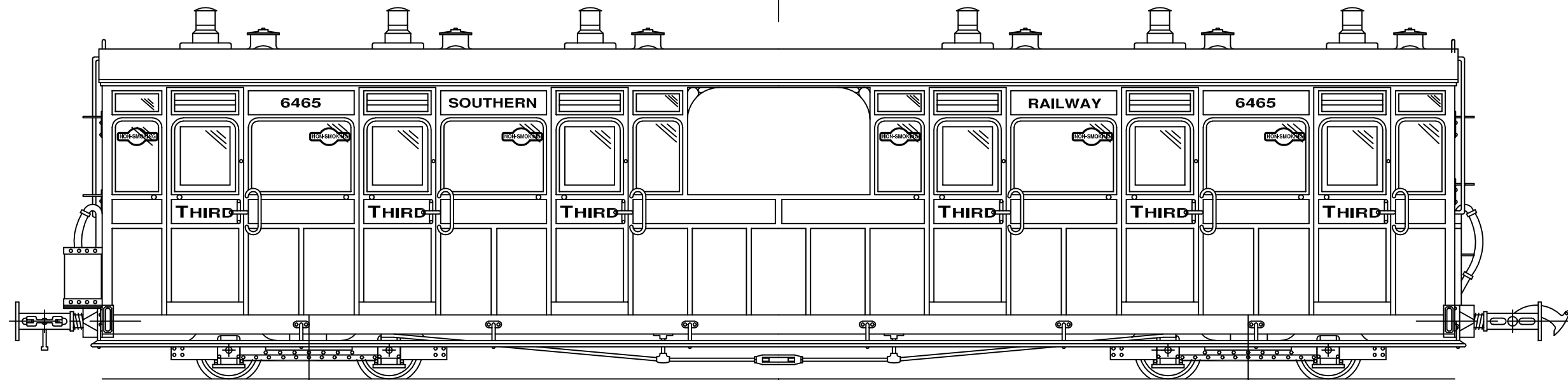

COACH Nos. 7, 8, 9 & 10 - THIRD WITH OPEN CENTRE SECTION
SOUTHERN RAILWAY Nos. 2465 TO 2468

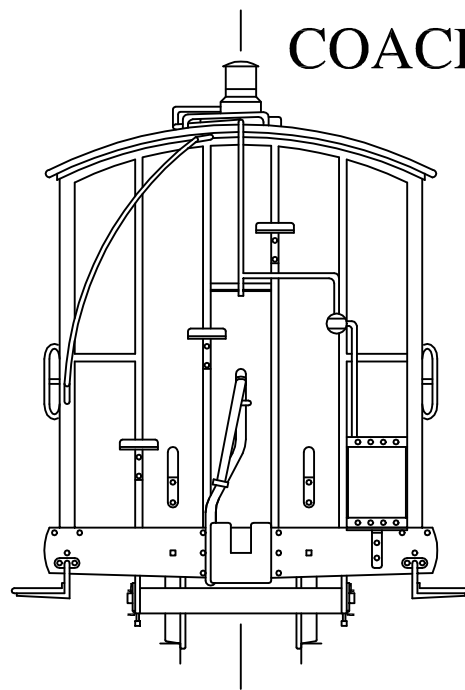

Length:
Width: 35' 2"
Height: 6' 0"
Weight: 8' 7"
Seats: 8Tons 16cwt
50 Third Class

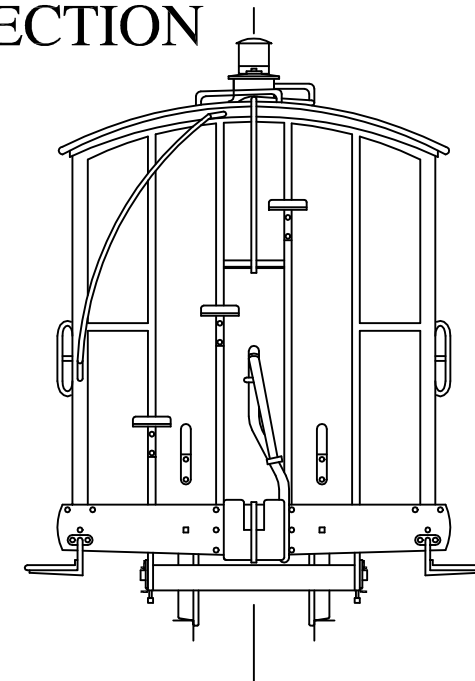

| |
|-------------------|
| Full Size: 10' |
| 4mm scale: 40mm |
| 7mm scale: 70mm |
| 16mm scale: 160mm |