

THE LYNTON AND BARNSTAPLE RAILWAY

Passenger Rolling Stock Built By
The Bristol Carriage & Wagon Works 1898

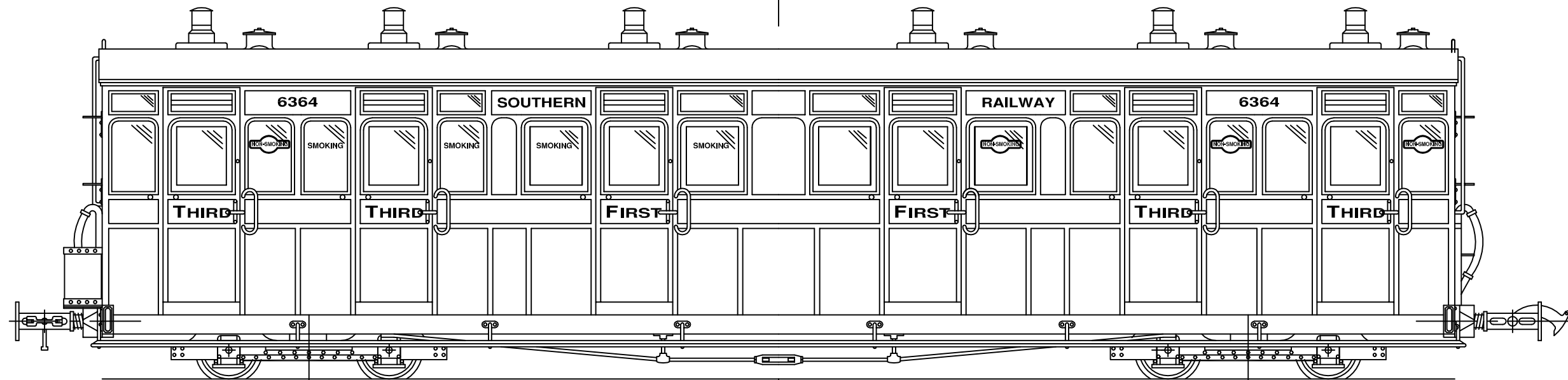

COACH Nos. 5 & 6 - COMPOSITE SOUTHERN RAILWAY Nos. 6364 AND 6365

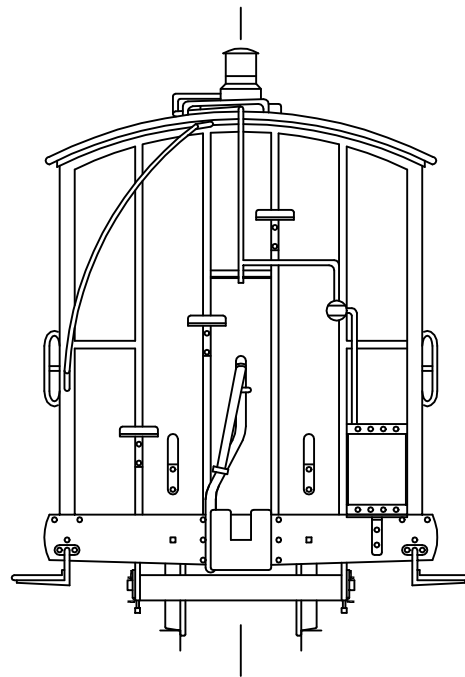

Length: 35' 2"
Width: 6' 0"
Height: 8' 7"
Weight: 8Tons 16cwt
Seats: 12 First Class
32 Third Class

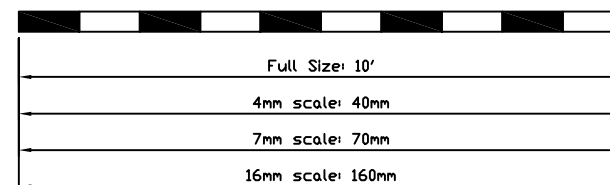
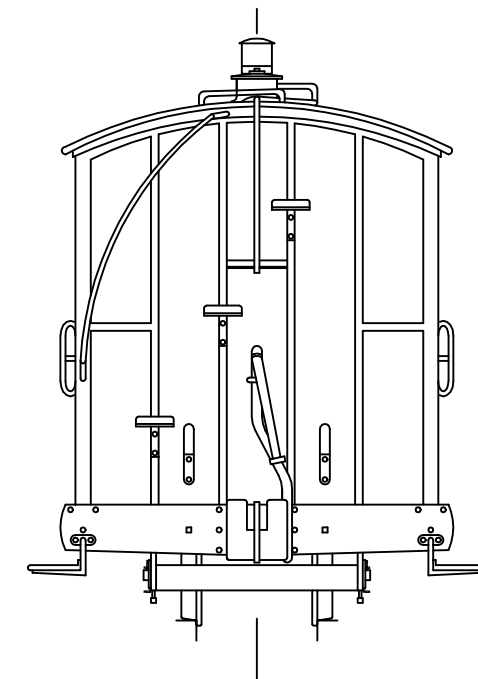

SCALE : 8mm = 1'
FILE : LBPRS05.DWG

R Wilkinson 1/2006