

THE LYNTON AND BARNSTAPLE RAILWAY

Passenger Rolling Stock Built By
The Bristol Carriage & Wagon Works 1898

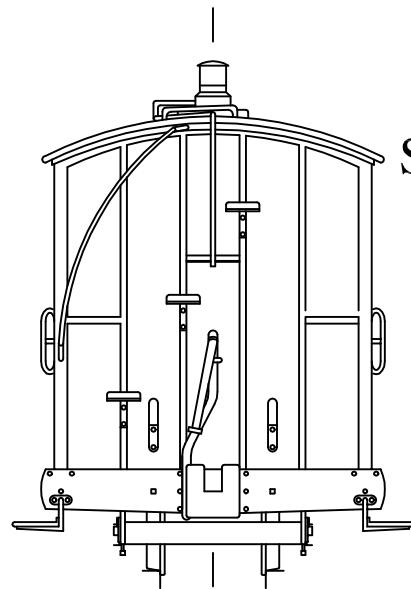
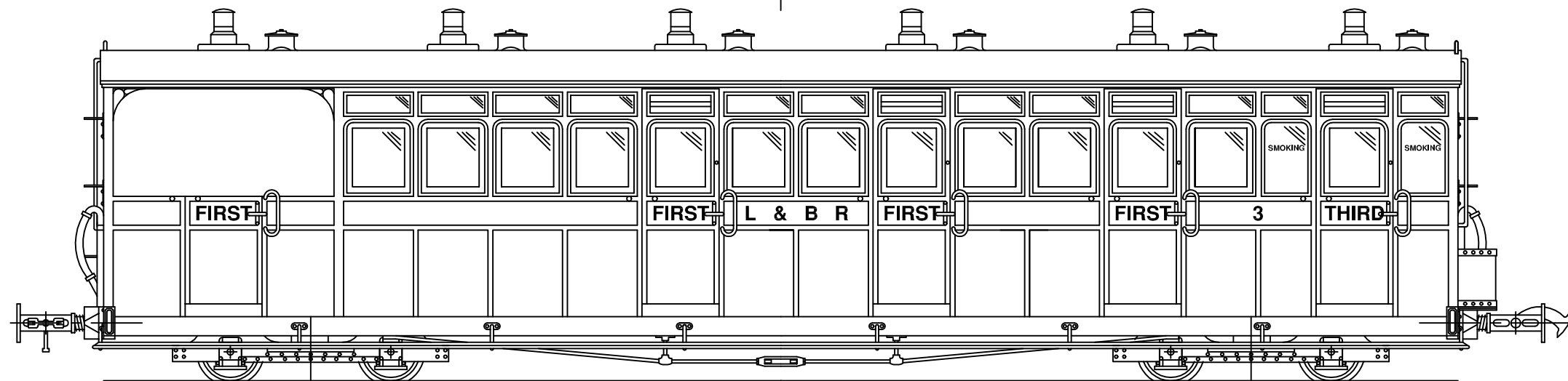

COACH Nos. 3 & 4 - COMPOSITE OBSERVATION SOUTHERN RAILWAY Nos. 2473 AND 2474 (THIRD)

Length: 35' 2"
Width: 6' 0"
Height: 8' 7"
Weight: 8Tons 16cwt
Seats: 30 First Class
8 Third Class

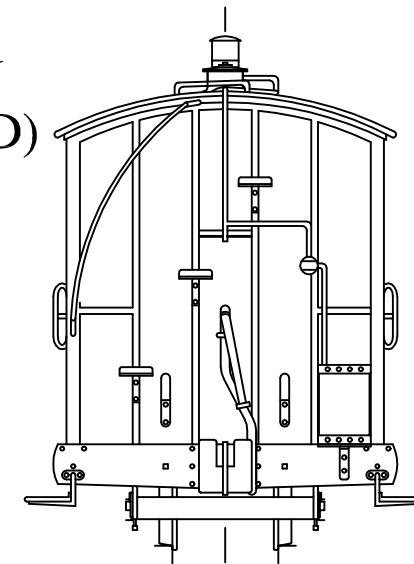

Full Size: 10'
4mm scale: 40mm
7mm scale: 70mm
16mm scale: 160mm

SCALE : 7mm = 1'
FILE : LBPRS03.DWG

R Wilkinson 1/2006