

# THE LYNTON AND BARNSTAPLE RAILWAY

Passenger Rolling Stock Built By  
The Bristol Carriage & Wagon Works 1898

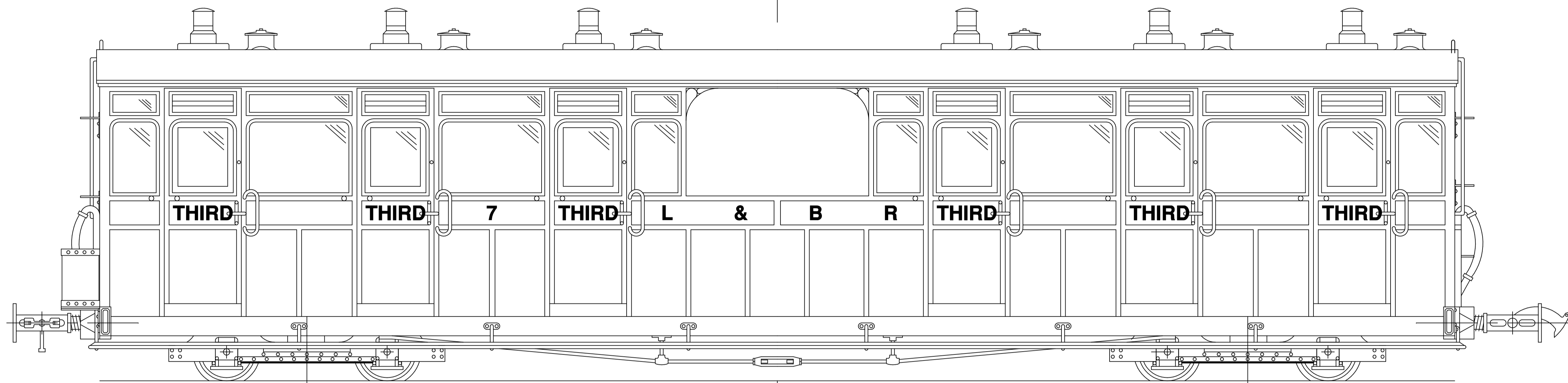

## COACH Nos. 7, 8, 9 & 10 - THIRD WITH OPEN CENTRE SECTION SOUTHERN RAILWAY Nos. 2465 TO 2468

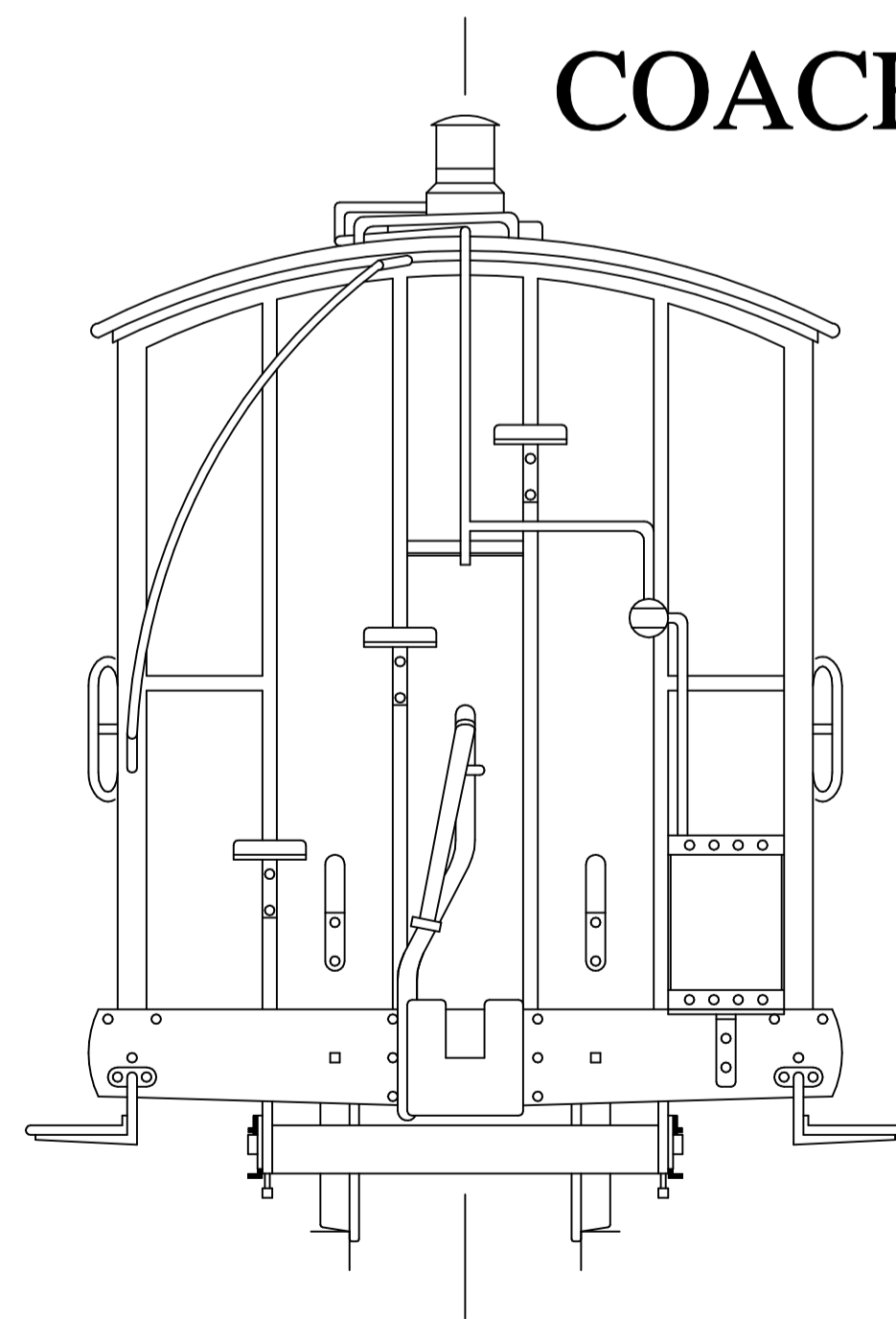

Length:  
Width: 35' 2"  
Height: 6' 0"  
Weight: 8' 7"  
Seats: 8Tons 16cwt  
50 Third Class

